



Classic Series

**C6 · 315-335W MWT Module
Mono 60 Cells**

20.6%

Module efficiency up to 20.6%

Benchmark MWT PV Module



High Efficiency

MWT back contact cell and modules with busbar-free design and higher efficiency



Superior Warranty

The only single-glass module with 30-year power warranty by LLOYD'S&PICC worldwide



High ROI

Higher return of investment with higher power output



High Reliability

Conductive back sheet 2D encapsulation without soldering, resulted lower degradation under multiple extreme testing condition



Aesthetic Design

Busbar-free design, unique and graceful finger pattern on the solar cell surface, customized pattern design also available



Lead Free

Eco-friendly PV design achieves Lead-free without soldering materials

Reinsurance Coverage for 30 Years



Insured by PICC and LLOYD'S

PICC LLOYD'S

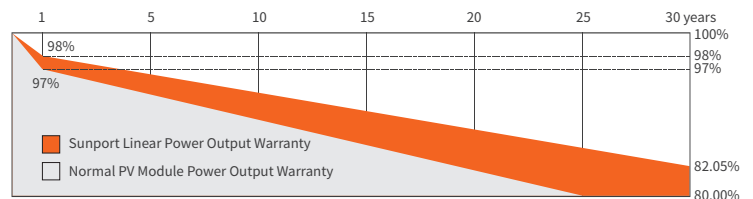

※1st year degradation less than 2%, 30 years linear power output 82% guaranteed.

Comprehensive Qualifications & Certifications

★CQC&CGC Top Runner Advanced Technology Certification (4A class)

★ISO 9001:2015 Quality Management System

★ISO 45001: 2018 Occupation Health Safety Management System

★ TUV NORD Certification

★ISO 14001:2015 Environment Management System



Jiangsu Sunport Power Corp.,Ltd

Add :No.20, Xishi Road, Xinwu District, Wuxi, China 214028

Email:info@sunportpower.com

Web:www.sunportpower.com

Electrical Characteristics at Standard Test Conditions(STC)

Spec/Model	Unit	SPP315M60H	SPP320M60H	SPP325M60H	SPP330M60H	SPP335M60H
Max-Power(Pm)	W	315	320	325	330	335
Power Tolerance	W			0~+5		
Max-Power Voltage(Vm)	V	32.2	32.4	32.6	32.8	33.0
Max-Power Current(Im)	A	9.79	9.88	9.97	10.07	10.16
Open-Circuit Voltage(Voc)	V	39.4	39.6	39.8	40.0	40.2
Short-Circuit Current(Isc)	A	10.28	10.36	10.44	10.52	10.62
Module Efficiency(ηm)	%	19.4	19.7	20.0	20.3	20.6

STC: AM=1.5, Irradiation 1000W/m², Module Temperature 25°C

Electrical Characteristics at Nominal Module Operating Temperature (NMOT)

Spec/Model	Unit	SPP315M60H	SPP320M60H	SPP325M60H	SPP330M60H	SPP335M60H
Max-Power(Pm)	W	236	240	244	248	251
Max-Power Voltage(Vm)	V	29.5	29.7	29.9	30.1	30.3
Max-Power Current(Im)	A	8.01	8.09	8.17	8.25	8.30
Open-Circuit Voltage(Voc)	V	36.0	36.1	36.2	36.3	36.5
Short-Circuit Current(Isc)	A	8.43	8.51	8.59	8.67	8.76

NMOT: Irradiation 800W/m², ambient temperature 20°C, Wind Speed 1m/s

Temperature Coefficient

Nominal Module Operating Temperature	43±2°C
Temperature coefficient of Pmax	-0.36%/°C
Temperature coefficient of Voc	-0.28%/°C
Temperature coefficient of Isc	0.06%/°C

Package

Transportation	Container Size	Quantity(pcs)	Quantity(per pallet)
Container	20' GP	372	31
Container	40' HC	868 / 938	31

Mechanical Characteristics

Dimension(L×W×H)	1640mmx992mmx35mm
Weight	18.5kg
Glass Type	High Transmittance Anti-reflective Coated Tempered Glass / 3.2mm
Solar Cell	60(10x6) / Mono / 158.75mm
Encapsulant	EVA
Frame	Anodized Aluminum Alloy / Silver
Junction Box	IP67 / IP68
Cable	1000mm / 4mm ²
Connector	MC4 Compatible

I-V Curve

I-V Curve at different irradiation (SPP325M60H)

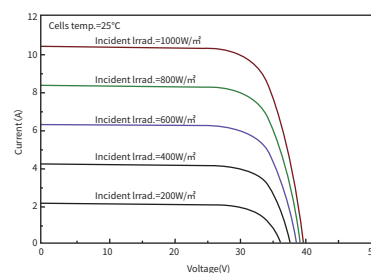

I-V Curve at different temperature (SPP325M60H)

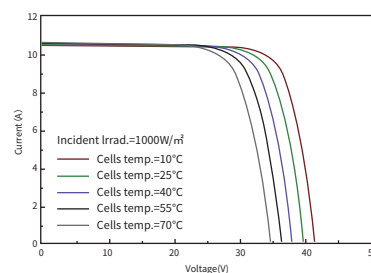

Module Size

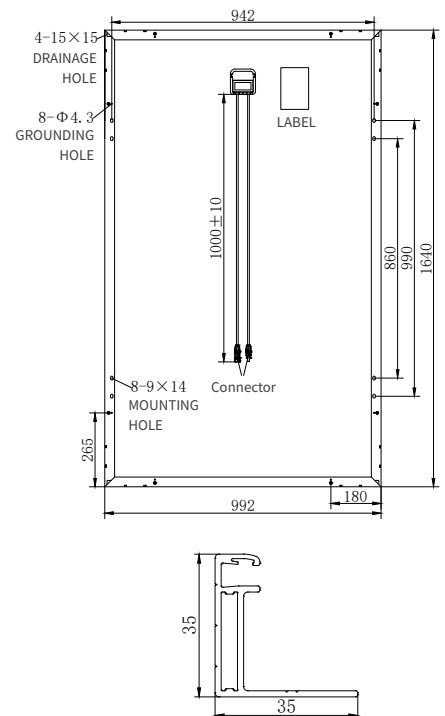

Operating Conditions

Max System Voltage	1500V(TUV)
Max Fuse Rated Current	15A
Operating Temperature Range	-40°C~+85°C
Mechanical Load	5400Pa (front) /2400Pa (rear)
Max Allowable Hail Load	φ25mm hail, from 1m of distance at 23 m/s
Application Class	Class A